

ROCUT 110 / 160

No. 55020, 55030, 55000, 55035, 55063, 55004, 55037

dated: 07/18

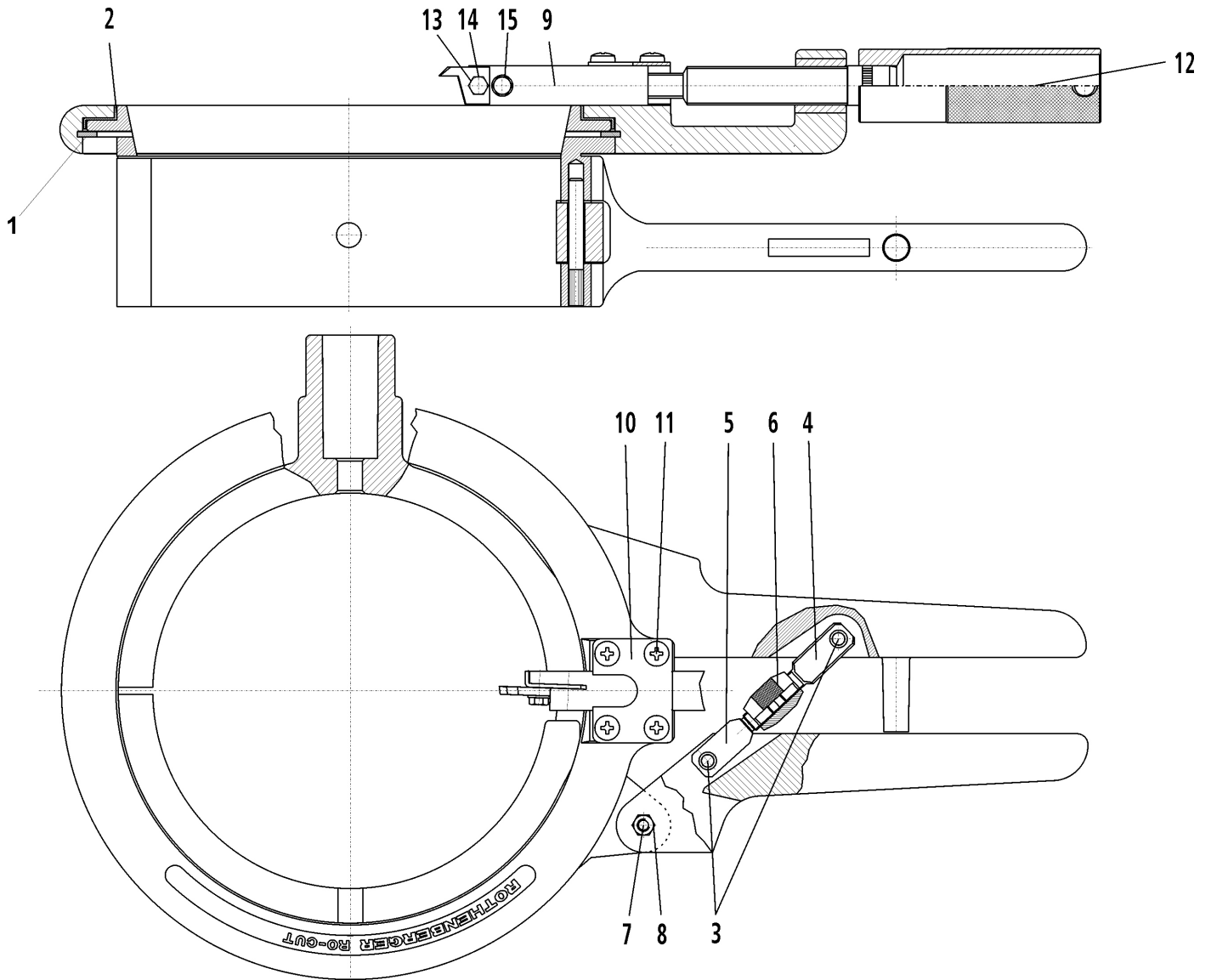

ROCUT 110 / 160

dated: 07/18

No. 55020, 55030, 55000, 55035, 55063, 55004, 55037

Item no.	Description	Article no.	Old article no.	Quantity
1	Locking ring ROCUT 110 (No. 55020)	F85031		1
1	Locking ring ROCUT 160 (No. 55030)	F85026		1
2	Slip-ring, size 2 ROCUT 110 (No. 55020)	F85010		1
2	Slip-ring, size 3 ROCUT 160 (No. 55030)	F85011		1
3	ROCUT Knurled bolt	1300003055	F85033	2
4	ROCUT Adjusting spindle M8x1	1300003054	F85034	1
5	ROCUT Adjusting spindle M8x1	1300003056	F85035	1
6	ROCUT Adjusting nut	1300003057	F85036	1
7	ROCUT Axis MS 5x28	F85590		1
8	ROCUTNut M5 DIN 985	F88487		2
9	Cutting plate shaft with automatic duplicating Ø 7,5 mm ROCUT 110	54960		1
9	Cutting plate shaft with automatic duplicating Ø 12,5 mm ROCUT 160	54961		1
9.1	HM cutting plate, Ø 7,5 mm ROCUT 110	55029		1
9.1	HM cutting plate, Ø 12,5 mm ROCUT 160	55019		1
10	ROCUT Plate for cutting plate shaft	F85051		1
11	ROCUT Fillister head screw M5x6	F88689		4
12	ROCUT Handle with spindle	1200001615		1
13	Cylinder head screw 4x12 Sz DIN 933	F88464		1
14	Washer 4.3 DIN 125	F88221		1
15	Cylinder head screw M4x10 DIN 912	L82308		1

IMPORTANT! To assure safety and reliability, repairs, maintenance and adjustment must be performed by ROTHENBERGER Kelkheim or authorized Service-Centers. Always use Original-Service-Parts. Order your accessories and spare parts from your specialist retailer or using RoService+ online.

Tel. +49 6195 - 800 **8200**

Fax: +49 6195 - 800 **7491**

 service@rothenberger.com